

## Operator's Instruction Manual

# EDCO VAC-290&VAC-200 INDUSTRIAL VACUUM SYSTEMS



**VAC-290**



**VAC-200**

## Manual - Portable Dry Dust Removal



**EQUIPMENT DEVELOPMENT COMPANY, INC.**

100 Thomas Johnson Drive, Frederick, MD 21702-4600 USA

Phone: 800-638-3326 or 301-663-1600 • Fax: 800-447-3326 or 301-663-1607

Website: [www.edcoinc.com](http://www.edcoinc.com) • E-mail: [sales@edcoinc.com](mailto:sales@edcoinc.com)

Printed in USA

©2017

E-VAC290&amp;VAC200-I-1017

**READ AND UNDERSTAND THE OPERATORS INSTRUCTION MANUAL THOROUGHLY  
BEFORE ATTEMPTING TO OPERATE THIS EQUIPMENT.****Death or serious injury could occur if this machine is used improperly.****SAFETY MESSAGES**

- Safety Instructions are preceded by a graphic alert symbol of DANGER, WARNING, or CAUTION.



Indicates an imminent hazard which, if not avoided, will result in death or serious injury.



Indicates an imminent hazard which, if not avoided, can result in death or serious injury.



Indicates hazards which, if not avoided, could result in serious injury and or damage to the equipment.

**GASOLINE/PROPANE POWERED EQUIPMENT**

- Engine exhaust from this product contains chemicals known to the State of California to cause cancer, birth defects or other reproductive harm.



- Gasoline is extremely flammable and poisonous. It should only be dispensed in well ventilated areas, and with a cool engine.

- Small gasoline engines produce high concentrations of carbon monoxide (CO) example: a 5 HP 4 cycle engine operation in an enclosed 100,000 cu. ft. area with only one change of air per hour is capable of providing deadly concentrations of CO in less than fifteen minutes. Five changes of air in the same area will produce noxious fumes in less than 30 minutes. Gasoline or propane powered equipment should not be used in enclosed or partially enclosed areas. Symptoms of CO poisoning include, headache, nausea, weakness, dizziness, visual problems and loss of consciousness. If symptoms occur - get into fresh air and seek medical attention immediately.

**ELECTRICAL POWERED EQUIPMENT**

Extreme care must be taken when operating electric models with water present: Ensure power cord is properly grounded, is attached to a Ground-Fault-Interrupter (GFI) outlet, and is undamaged.

- Check all electrical cables - be sure connections are tight and cable is continuous and in good condition. Be sure cable is correctly rated for both the operating current and voltage of this equipment.
- Improper connection of the equipment-grounding conductor can result in a risk of electric shock. Check with qualified electrician or service person if there is any doubt as to whether the outlet is properly grounded. Adhere to all local codes and ordinances.
- **NOTE:** In the event of a malfunction or breakdown, grounding provides a path of least resistance for the electric current to dissipate. The motor is equipped with a grounded plug and must be connected to an outlet that is properly installed and properly grounded. DO NOT modify the plug provided on the motor. If the plug does not fit the outlet have a qualified electrician install the proper receptacle.
- Switch motor OFF before disconnecting power.

- Do not disconnect power by pulling cord. To disconnect, grasp the plug, not the cord.
- Unplug power cord at the machine when not in use and before servicing.

**GENERAL INSTRUCTIONS**

- Equipment should only be operated by trained personnel in good physical condition and mental health (not fatigued). The operator and maintenance personnel must be physically able to handle the bulk weight and power of this equipment.
- This is a one person tool. Maintain a safe operating distance to other personnel. It is the **operators' responsibility** to keep other people (workers, pedestrians, bystanders, etc.) away during operation. Block off the work area in all directions with roping, safety netting, etc. for a safe distance. Failure to do so may result in others being injured by flying debris or exposing them to harmful dust and noise.
- This equipment is intended for commercial use only.
- For the operator's safety and the safety of others, always keep all guards in place during operation.
- Never let equipment run unattended.



- Personal Protection Equipment and proper safety attire must be worn when operating this machinery. The operator must wear approved safety equipment appropriate for the job such as hard hat and safety shoes when conditions require. Hearing protection **MUST** be used (operational noise levels of this equipment may exceed 85db). Eye protection **MUST** be worn at all times.



Keep body parts and loose clothing away from moving parts. Failure to do so could result in dismemberment or death.

- Do not modify the machine.
- Stop motor/engine when adjusting or servicing this equipment.



Maintain a safe operating distance from flammable materials. Sparks from the cutting-action of this machine can ignite flammable materials or vapors.

**DUST WARNING**

Some dust created by power sanding, sawing, grinding, drilling, and other construction activities contains chemicals known to cause cancer, birth defects, or other reproductive harm. Some examples of these chemicals are:

- Lead from lead-based paints, and
- Crystalline silica from bricks and concrete and other masonry products.

Your risk of exposure to these chemicals varies depending on how often you do this type of work. To reduce your risk: work in a well ventilated area, use a dust control system, such as an industrial-style vacuum, and wear approved personal safety equipment, such as a dust/particle respirator designed to filter out microscopic particles.

## Table of Contents

<u>Section</u>	<u>Page Number</u>
Safety Instructions.....	2
Specifications.....	3
Start Up.....	4
Inspection & Maintenance VAC-200.....	5
HEPA 2.0 Replacement.....	6
Inspection & Filter Maintenance VAC-290.....	7-8
Motor Brush Inspection.....	9
Trouble Shooting VAC-200 & VAC-290.....	10
Limited Equipment Warranty.....	11

## SPECIFICATIONS

Note:  
All dimensions and weights are for **reference only** and subject to change at any time.



Note: VAC-290  
Shown

**Figure 1**

### HOW TO ORDER REPAIR PARTS

To insure product safety and reliability, always use genuine EDCO replacement parts when making repairs to the equipment.

When ordering parts, please specify the MODEL and SERIAL NUMBER of the machine as given on the NAMEPLATE. In addition, give part number, description and quantity as listed on the parts list.

Please note: Due to improvements and changes in the equipment the illustrations shown may be different from the actual machine.

Toll Free: Phone 1-800-638-3326 • Fax 1-800-447-3326

	VAC-290	VAC-200
"A"	20" (50.8mm)	20" (50.8mm)
"B"	51" (129.5mm)	35" (89mm)
"C"	32" (81mm)	32" (81mm)
Weight	169 lbs. (76.6kg)	90 lbs. (40.8kg)



### EQUIPMENT DEVELOPMENT COMPANY, INC.

100 Thomas Johnson Drive, Frederick, MD 21702-4600 USA  
Phone: 800-638-3326 or 301-663-1600 • Fax: 800-447-3326 or 301-663-1607  
Website: www.edcoinc.com • E-mail: sales@edcoinc.com

Printed in USA

©2017

Page 3

E-VAC290&VAC200-I-1017

NOTE: The following instructions are for models VAC-200 & VAC-290 except where noted. The instructions are very similar but are different in several ways. Please pay special attention where differences are noted for models.

## Safety VAC-200 & VAC-290

CAUTION: Standard EDCO machines are not to be used for the removal of liquids or any volatile, viscous, flammable or explosive media. If you are unsure about your application requirements consult your EDCO representative.

CAUTION: Standard EDCO VAC machines are designed for intermittent use, i.e. not more than 2 hours continuously. If you are unsure about your application requirements consult your EDCO representative.

CAUTION: A dust mask should be worn when working with used filters.

CAUTION: Disconnect the machine from the power source before and during inspection and/or maintenance.

CAUTION: Machines equipped with a reverse pulse module must always be supplied adequately when the machine is on. The module is controlled by an electrical sequential timer (requires a 110 volt power supply) or differential pressure switch. The module itself requires a source of compressed air of 90 PSI at 2-4 CFM (depending on module). This device prevents the accumulation of material on the filter and therefore prevents the machine from being held under excessive stresses due to material blockage.

CAUTION: Machines equipped with a motorized shaker must be supplied with a three phase, 230-460 volt (depending on motor) power supply when ever the machine is on. The motorized shaker is controlled by an electrical sequential timer (requires a 110 volt power supply), a differential pressure switch or a manual switch. Manual switch models should be actuated before and after every use while the vacuum is off. This device prevents the accumulation of material on the filter and therefore prevents the machine from being held under excessive stresses due to material blockage.

## Start-Up VAC-200

1. Pull up on the foot lever to release the dustpan. Check that the dustpan is completely empty then replace.

CAUTION: The electrical service at the installation site must supply the voltage stamped on the machine's serial tag. Most motors have multiple voltage capabilities that may appear on the motor serial tag but do not apply to the specific machine. Operating at an incorrect voltage may damage the machine.

NOTE: A qualified electrician in accordance with the National Electric Code and all local codes should perform all wiring and/or electrical adjustments during installation and servicing.

2. Connect the machine to the proper power source, as indicated on the machine's serial tag.
3. Start the machine by pushing the power switches on the motors to the ON/closed position one at a time.
4. Turn the machine off by pushing the power switches on the motors to the OFF/open position.
5. The filter should be shaken and the dustpan emptied before and after every use.

## Start-Up VAC-290

1. Pull up on the foot lever to release the dustpan. Check that the dustpan is completely empty then replace.

CAUTION: The electrical service at the installation site must supply the voltage stamped on the machine's serial tag. Most motors have multiple voltage capabilities that may appear on the motor serial tag but do not apply to the specific machine. Operating at an incorrect voltage may damage the machine.

NOTE: A qualified electrician in accordance with the National Electric Code and all local codes should perform all wiring and/or electrical adjustments during installation and servicing.

2. Connect the machine to the proper power source, as indicated on the machine's serial tag.
3. Start the machine by pushing the power switches on the control panel to the ON/closed position one at a time.
4. Turn the machine off by pushing the power switches on the control panel to the OFF/open position.
5. The filter should be shaken and the dustpan emptied before and after every use.

# Inspection and Maintenance VAC-200

## Standard Filter Inspection

1. Turn the machine off.
2. Knock material off the filter via the hand shaker, motorized shaker or reverse pulse.
3. Pull up on the foot lever to release the dustpan then remove and empty if necessary.
4. Lock the rear casters then carefully tip the machine back onto the push handle.
5. Remove any material between the pleats, by hand only.

CAUTION: Clogged material should only be removed by hand. Using an object to dislodge material may tear the filter. Consult your EDCO representative if material blockage is excessive.

6. Inspect the pleats of the filter for tears and material blockage.
7. Carefully tip the machine back onto the casters and replace the dustpan.

## Standard Filter Removal

1. First follow the preceding filter inspection procedure to determine if removal is necessary.
2. Turn the machine on then block the inlet with a flat and rigid material to place the machine under vacuum pressure.
3. Remove all of the housing-component socket truss screws with a 5/32 hex-wrench.
4. Turn the machine off and disconnect the power source.
5. Separate the motor deck from the housing then disconnect the motor deck ground wire from the push-on terminal.
6. Disconnect the three power cord wires from the terminal block on the underside of the motor deck.
7. Remove the motor deck.
8. Disconnect the clear differential pressure gage tubes from their respective barbed fittings if so equipped.
9. Remove the HEPA filter housing spacer and HEPA adapter assembly if so equipped; make sure to disconnect the HEPA adapter assembly ground wire via push-on terminal before removing.
10. Remove the reverse pulse/motorized shaker assembly and housing spacer if so equipped; make sure to disconnect the component ground wire via push-on terminal before removing.
11. Inspect the top of the filter for material.

NOTE: The presence of material in this area or in the exhaust is often the result of a misaligned seal or damaged filter. Consult your EDCO representative if either is the case.

12. Remove the filter housing spacer assembly; make sure to disconnect the filter housing spacer assembly ground wire from the base via push on terminal.
13. Turn the filter housing spacer assembly over on a table then work the filter off the filter shaker insert.

## Motor Brushes Inspection

1. Turn the machine off then disconnect the power source.
2. Disconnect both motor terminals.
3. Loosen the motor retaining knobs enough to remove both motors.
4. Remove the 12 screws from the bottoms of the motor assemblies.
5. Remove the plastic motor covers to access the tops of the motors.
6. Remove the 2 metal motor-cap-retaining clips per motor.
7. Carefully dislodge the plastic motor cap via the built in hooks on both sides of each motor brush.  
(TIP: Dislodge one side of a cap first, then the other.)
8. Remove the motor brush retainers via the 2 phillips screws per brush.
9. Remove each of the brushes and inspect for excessive or uneven wear.

NOTE: A brush should be replaced if its length is less than 0.25 inches.

10. Reverse the procedure to install the brushes.
11. Reassemble and secure both motor assemblies with the 12 motor cover screws. Do not over tighten the screws, as the cover will crack.
12. Position both motors in the deck and secure with the motor retaining knobs.
13. Connect both motor terminals.



## EQUIPMENT DEVELOPMENT COMPANY, INC.

100 Thomas Johnson Drive, Frederick, MD 21702-4600 USA  
Phone: 800-638-3326 or 301-663-1600 • Fax: 800-447-3326 or 301-663-1607  
Website: [www.edcoinc.com](http://www.edcoinc.com) • E-mail: [sales@edcoinc.com](mailto:sales@edcoinc.com)

Printed in USA

©2017

Page 5

## Standard Filter Installation VAC-200

1. Turn the filter housing spacer assembly over on a table then fit the filter over the filter shaker insert.
2. Make sure each pleat is fully supported and the ground wire is on the filter side of the assembly.
3. Connect the filter housing spacer assembly ground wire to the base via the push-on terminal.
4. Seat the filter housing spacer assembly on the base oriented as it was removed.
5. Seat the reverse pulse/motorized shaker assembly and housing spacer (if so equipped) on the filter housing spacer assembly oriented as removed; make sure to connect the component ground wire to the filter housing spacer assembly via push-on terminal.
6. Seat the HEPA adapter assembly and housing spacer (if so equipped) on the preceding housing component oriented as removed; make sure to connect the component ground wire to the preceding assembly via push on terminal.
7. Connect the motor deck ground wire to the preceding assembly.
8. Connect the three power cord wires to their respective terminals in the terminal block on the underside of the motor deck.
9. Seat the motor deck on the preceding housing spacer.
10. Connect the clear differential pressure gauge tubes to their respective barbed fittings if so equipped.
11. Turn the machine on then block the inlet with a flat and rigid material to place the machine under vacuum pressure.
12. Secure all of the housing-components then turn the machine off.

## HEPA 2.0 Filter Replacement Procedure VAC-200

1. Turn the machine on then block the inlet with a flat rigid material to place the machine under vacuum pressure.
2. Remove hardware, motor deck and motors. Remove ground wire if necessary.
3. Turn assembly over.
4. Remove lock nut, nut, and washer on each cartridge.
5. Remove cartridge filter.
6. Install cleaned or new cartridge and re-assemble hardware.
7. Reinstall motor deck. Attach ground wire.
8. Turn on motors and block inlet to compress the housings.
9. Reinstall hardware.

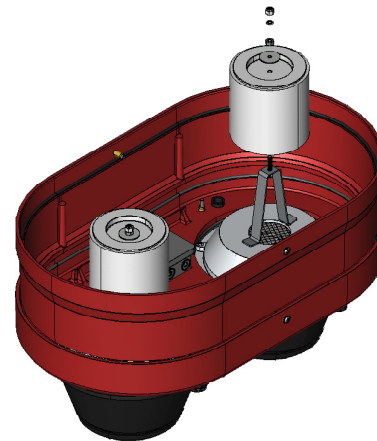

## Inspection and Maintenance VAC-290

### Standard Filter Inspection

1. Turn the machine off.
2. Knock material off the filter via the hand shaker, motorized shaker or reverse pulse.
3. Pull up on the foot lever to release the dustpan then remove and empty if necessary.
4. Lock the rear casters then carefully tip the machine back onto the push handle.
5. Remove any material between the pleats, by hand only.

CAUTION: Clogged material should only be removed by hand. Using an object to dislodge material may tear the filter. Consult your EDCO representative if material blockage is excessive.

6. Inspect the pleats of the filter for tears and material blockage.
7. Carefully tip the machine back onto the casters and replace the dustpan.

### Standard Filter Removal

1. Follow the preceding filter inspection procedure to determine if removal is necessary.
2. Turn the machine on then block the inlet with a flat and rigid material to place the machine under vacuum pressure.
3. Remove all of the housing-component socket truss screws with a 5/32 hex-wrench.
4. Turn the machine off and disconnect the power source.
5. Separate the motor deck from the housing then disconnect the motor deck ground wire from the push-on terminal.
6. Remove the motor deck.
7. Disconnect the clear differential pressure gauge tubes from their respective barbed fittings if so equipped.
8. Remove the HEPA filter housing spacer and HEPA adapter assembly if so equipped; make sure to disconnect the HEPA adapter assembly ground wire via push-on terminal before removing.
9. Remove the reverse pulse/motorized shaker assembly and housing spacer if so equipped; make sure to disconnect the component ground wire via push-on terminal before removing.
10. Inspect the top of the filter for material.

#### NOTE:

The presence of material in this area or in the exhaust is often the result of a misaligned seal or damaged filter. Consult your EDCO representative if either is the case.

11. Remove the filter housing spacer assembly; make sure to disconnect the ground wire via push on terminal.

## Standard Filter Installation VAC-290

1. Turn the filter housing spacer assembly over on a table then fit the filter over the filter shaker insert.
2. Make sure each pleat is fully supported and the ground wire is on the filter side of the assembly.
3. Connect the filter housing spacer assembly ground wire to the base via the push-on terminal.
4. Seat the filter housing spacer assembly on the base oriented as it was removed.
5. Seat the reverse pulse/motorized shaker assembly and housing spacer (if so equipped) on the filter housing spacer assembly oriented as removed; make sure to connect the component ground wire to the filter housing spacer assembly via push-on terminal.
6. Seat the HEPA adapter assembly and housing spacer (if so equipped) on the preceding housing component oriented as removed; make sure to connect the component ground wire to the preceding assembly via push on terminal.
7. Connect the motor deck ground wire to the preceding assembly then seat the deck on the preceding housing spacer.
8. Connect the clear differential pressure gauge tubes to their respective barbed fittings if so equipped.
9. Turn the machine on then block the inlet with a flat and rigid material to place the machine under vacuum pressure.
10. Secure all of the housing-components then turn the machine off.



**EQUIPMENT DEVELOPMENT COMPANY, INC.**  
100 Thomas Johnson Drive, Frederick, MD 21702-4600 USA  
Phone: 800-638-3326 or 301-663-1600 • Fax: 800-447-3326 or 301-663-1607  
Website: [www.edcoinc.com](http://www.edcoinc.com) • E-mail: [sales@edcoinc.com](mailto:sales@edcoinc.com)

Printed in USA

©2017

Page 7

## HEPA MAXX Filter Replacement Procedure VAC-290

NOTE: All HEPA MAXX filter machines are equipped with a differential pressure gauge. The gauge measures the pressure above against the pressure below the filter, thereby measuring the restriction of airflow due to contamination. HEPA filters should be replaced when the gauge consistently measures 8 inches W.C.

1. Turn the machine on then block the inlet with a flat and rigid material to place the machine under vacuum pressure.
2. Remove the motor deck hardware. Figure 1
3. Turn the machine off and disconnect the power source.
4. Separate the motor deck and HEPA filter housing spacer then disconnect the motor deck ground wire from the HEPA adapter assembly via the push-on terminal. Figure 2
5. Remove the motor deck and silencer hood together.
6. Remove the lock nuts retaining the HEPA filter brackets. Figure 3
7. Remove the ring-to-tab terminal, HEPA filter brackets and HEPA filter.
8. Center the new filter on the HEPA adapter plate gasket side down. Figure 4
9. Position the provided lengths of self-adhering flat gasket material on the HEPA filter frame (if not already done so) to cushion the HEPA filter brackets.
10. Replace the HEPA filter brackets and ring-to-tab terminal then thread the locking nuts over the rods and tighten. Figure 5

CAUTION: Do not over tighten. The effectiveness of the filter may be compromised if its frame is bent.

11. Set the motor deck on the HEPA filter housing spacer.
12. Connect the motor deck ground wire to the HEPA adapter plate assembly via the push-on terminal then seat the deck on the HEPA filter housing spacer. Figure 7
13. Connect the power source.
14. Turn the machine on then block the inlet with a flat and rigid material to place the machine under vacuum pressure.
15. Secure the motor deck then turn the machine off. Figure 8





## Motor Brushes Inspection

1. Turn the machine off then disconnect the power source. Figure 1
2. Disconnect motor terminal. Figure 2
3. Loosen the motor retaining knobs. Figure 3
4. Remove the 6 screws attached to each motor assembly. Figure 4
5. Remove the plastic motor cover to access the top of the motor. Figure 5
6. Remove the 2 metal motor cap retaining clips located on each motor.(Ametec only). Figure 6



## Ametec

1. Remove the motor fan cover by pressing down on clips located on each side. Figure 1
2. Remove the 2 screws securing the brush. Repeat the process for the other side. Figure 2
3. Pull brush out of wire clip. Figure 3
4. Remove brush from wire clip by sliding off groove. If brush is worn down to a length of 0.25" or less, replace. Fig. 4

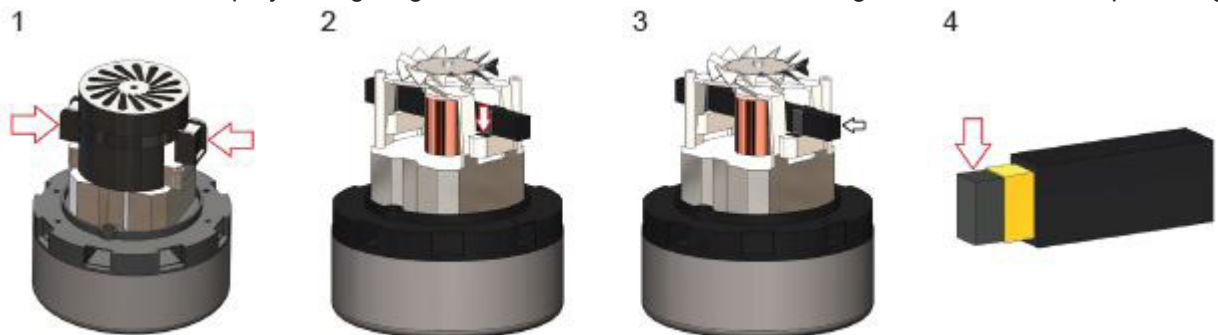

## Electro

1. Carefully dislodge the plastic motor cap via the built in hooks on both side of the motor brush.(TIP: Dislodge one side of the cap first followed by the other.) Figure 1
2. With a flathead screwdriver, flip brush tab upward. Use pliers to then pull the brush out by the tab. Figure 2
3. If the brush is worn down to a length of 0.25" or less, replace the brush. Figure 3
4. To reinstall the brush hold down internal spring using the tool supplied with the brush. While holding the spring down, push the brush back in. Remove the brush tool once the brush is in. Push the brush in until it's flush. Figure 4

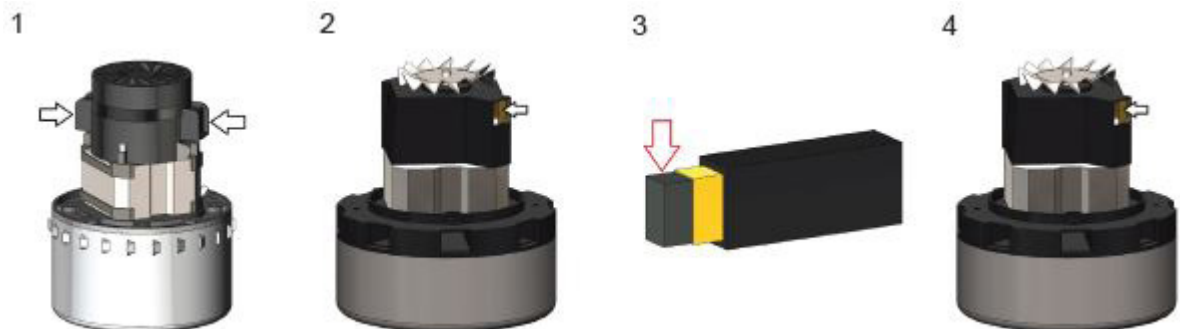

# Trouble Shooting VAC-290 & VAC-200

PROBLEM	POSSIBLE CAUSE	CORRECTIVE ACTION
Insufficient Vacuum Pressure	- Motors are not on and/or working	- Turn both motors on, check motor brushes
	- Dustpan improperly seated	- Remove dustpan, inspect seal, replace dustpan.
	- Filter clogged or improperly seated	- Follow filter inspection procedure, page 6.
	- Clogged hose	- Remove hose and re-inspect vacuum pressure, if vacuum pressure returns to normal snake hose.
	- Unit is improperly sealed	- Block the inlet with a flat and rigid material to place the unit under vacuum pressure then inspect for air leaks.
Air Leaks	- Worn or poorly seated seals,	- Block the inlet with a flat and rigid material to place the unit under vacuum pressure then remove retainers and turn the unit off. Inspect the seals for completeness, then reseal and secure components again under vacuum pressure.
Material In Exhaust/ On Top Side of Filter	- Poor filter seal or torn filter	- Follow filter inspection procedure in Inspection and Maintenance section.
Unusual or High Pitched Noises	- Motor bearings, Motor brushes	- Follow relevant motor brushes inspection procedure in Inspection and Maintenance section. Check motor bearings for noise by hand.
	- Worn or poorly seated seals, Retainers improperly installed	- Block the inlet with a flat and rigid material to place the unit under vacuum pressure then remove retainers and turn the unit off. Inspect the seals for damage, then reseal and secure components again under vacuum pressure.

## SMI Dust and Silica Warning

Grinding/cutting/drilling of masonry, concrete, metal and other materials can generate dust, mists and fumes containing chemicals known to cause serious or fatal injury or illness, such as respiratory disease, cancer, birth defects or other reproductive harm. If you are unfamiliar with the risks associated with the particular process and/or material being cut or the composition of the tool being used, review the material safety data sheets and/or consult your employer, the manufacturers/suppliers, governmental agencies such as OSHA and NIOSH and other sources on hazardous materials. California and some other authorities, for instance, have published lists of substances known to cause cancer, reproductive toxicity, or other harmful effects.

Control dust, mist and fumes at the source where possible. In this regard use good work practices and follow the recommendations of the manufacturers/suppliers, OSHA/NIOSH, and occupational and trade associations. Water should be used for dust suppression when wet grinding/cutting/drilling is feasible. When the hazards from inhalation of dust, mists and fumes cannot be eliminated, the operator and any bystanders should always wear a respirator approved by NIOSH/MSHA for the material being used.

Grinding/cutting/drilling of masonry, concrete and other materials with silica in their composition may give off dust or mists containing crystalline silica. Silica is a basic component of sand, quartz, brick clay, granite and numerous other minerals and rocks. Repeated and/or substantial inhalation of airborne crystalline silica can cause serious or fatal respiratory diseases, including silicosis. In addition, California and some other authorities have listed respirable crystalline silica as a substance known to cause cancer. When grinding/cutting/drilling such materials, always follow the respiratory precautions mentioned above.

**LIMITED EQUIPMENT WARRANTY OF SALE – TERMS & CONDITIONS**

Equipment Development Company, Inc. herein referred to as EDCO (Seller) warrants that each new unit manufactured by EDCO to be free from defects in material and workmanship in normal use and service for a period of (1) one year (except for the cutter drum assembly on all model concrete/asphalt planes, in which case the warranty period shall be 90 days) from date of shipment to the original retail or equipment rental center owner.

Accessories or equipment furnished and installed on the product by EDCO but manufactured by others, including, but not limited to engines, motors, electrical components, transmissions etc., shall carry the accessory manufacturers own warranty.

EDCO will, at its option, repair or replace, at the EDCO factory or at a point designated by EDCO, any part which shall appear to the satisfaction of EDCO inspection to have been defective in material or workmanship.

EDCO reserves the right to modify, alter and improve any part or parts without incurring any obligation to replace any part or parts previously sold without such modified, altered or improved part or parts.

This warranty is in lieu of and excludes all other warranties, expressed, implied, statutory, or otherwise created under applicable law including, but not limited to the warranty of merchantability and the warranty of fitness for a particular purpose in no event shall seller or the manufacturer of the product be liable for special, incidental, or consequential damages, including loss of profits, whether or not caused by or resulting from the negligence of seller and/or the manufacturer of the product unless specifically provided herein. In addition, this warranty shall not apply to any products or portions thereof which have been subjected to abuse, misuse, improper installation, maintenance, or operation, electrical failure or abnormal conditions and to products which have been tampered with, altered, modified, repaired, reworked by anyone not approved by seller or used in any manner inconsistent with the provisions of the above or any instructions or specifications provided with or for the product

**FORCE MAJEURE**

Seller's obligation hereunder are subject to, and Seller shall not be held responsible for, any delay or failure to make delivery of all or any part of the Product due to labor difficulties, fires, casualties, accidents, acts of the elements, acts of God, transportation difficulties, delays by a common carrier, inability to obtain Product, materials or components or qualified labor sufficient to timely perform part of or all of the obligations contained in these terms and conditions, governmental regulations or actions, strikes, damage to or destruction in whole or part of manufacturing plant, riots, terrorist attacks or incidents, civil commotions, warlike conditions, flood, tidal waves, typhoon, hurricane, earthquake, lightning, explosion or any other causes, contingencies or circumstances within or without the United States not subject to the Seller's control which prevent or hinder the manufacture or delivery of the Products or make the fulfillment of these terms and conditions impracticable. In the event of the occurrence of any of the foregoing, at the option of Seller, Seller shall be excused from the performance under these Terms and Conditions, or the performance of the Seller shall be correspondingly extended.

This document sets forth the terms and conditions pursuant to which the purchaser ("Purchaser") will purchase and Equipment Development Co. Inc. ("Seller") will sell the products, accessories, attachments (collectively the Products) ordered by the Purchaser. These terms and conditions shall govern and apply to the sale of Seller's Products to Purchaser, regardless of any terms and conditions appearing on any purchase order or other forms submitted by Purchaser to Seller, or the inconsistency of any terms therein and herein.

**1. PRICE**

All prices set forth on any purchase order or other document are F.O.B. Sellers facility or distribution point, as may be determined by Seller (F.O.B. Point). All prices are exclusive of any and all taxes, including, but not limited to, excise, sales, use, property or transportation taxes related to the sale or use of the Products, now or hereafter imposed, together with all penalties and expenses. Purchaser shall be responsible for collecting and/or paying any and all such taxes, whether or not they are stated in any invoice for the Products. Unless otherwise specified herein, all prices are exclusive of inland transportation, freight, insurance and other costs and expenses relating to the shipment of the Products from the F.O.B. point to Purchaser's facility. Any prepayment by Seller of freight insurance and other costs shall be for the account of Purchaser and shall be repaid to Seller.

**2. PAYMENT TERMS**

Payment terms are as follows. 2% 10 days (to approved and qualified accounts). Net 30 days. This is a cash discount for invoices paid within 10 days after the invoice date, regardless of date of receipt of shipment. This is not a trade discount and will not be granted to accounts that do not adhere to stated terms.

\*All past due accounts are subject to a late payment fee of 1.5% per month or a maximum allowed by law if different, along with the expenses incidental to collection including reasonable attorney's fees and costs.

\*Seller reserves the right to hold shipments against past due accounts.

\*Seller reserves the right to alter payment terms.

**3. FREIGHT TERMS**

All shipments will be made F.O.B. shipping point as designated in these Terms and Conditions, and title shall pass at the F.O.B. point. Delivery to the initial common carrier shall constitute delivery to the Purchaser. Any claims for loss or damage during shipment are to be filed with carrier by the Purchaser. Seller will not assume responsibility for the performance of the carrier.

Back orders will be shipped in the most practical fashion with charges consistent with our freight policy established with the original order. UPS, FED EX, MAIL or shipments by other couriers are subject to the same terms and conditions as outlined in paragraph #3 "Freight Terms".

**4. DELIVERY, DAMAGES, SHORTAGES**

Seller shall use reasonable efforts to attempt to cause the Products to be delivered as provided for in these Terms & Conditions. Delivery to the initial common carrier shall constitute the delivery to the Purchaser. Seller's responsibility, in so far as transportation risks are concerned ceases upon the delivery of the Products in good condition to such carrier at the F.O.B. point and all the Products shall be shipped at the Purchaser's risk. Seller shall not be responsible or liable for any loss of income and/or profits, or incidental, special, consequential damages resulting from Seller's delayed performance in shipment and delivery.

**5. RETURN OF DEFECTIVE PRODUCTS**

Defective or failed material shall be held at the Purchaser's premises until authorization has been granted by Seller to return or dispose of Products. Products that are to be returned for final inspection must be returned Freight Prepaid in the most economical way. Credit will be issued for material found to be defective upon Seller's inspection based on prices at time of purchase.

**6. PRODUCTS ORDERED IN ERROR**

Products may be returned, provided that claim is made and Seller is notified within 7 days of receipt of Products, and the Products are in original buyer's possession not more than 30 days prior to return, subject to Seller's approval. If Products are accepted for return, they must be Freight Prepaid and buyer will be charged a minimum of 15% restocking charge, plus a charge back for outbound freight charges if the original order was shipped prepaid. Returns are not accepted for any Products that are specifically manufactured to meet the buyer's requirement of either specifications or quantity.

**AGREEMENTS**

These Terms and Conditions constitute the entire agreement between Seller and Purchaser as it relates to terms and conditions of sale, and supersedes any and all prior oral or written agreements, correspondence, quotations or understandings heretofore in force between the parties relating to the subject matter hereof. There are no agreements between Seller and Purchaser with respect to the Product herein except those specifically set forth in and made part of these terms and conditions. Any additional terms, conditions and/or prices are rejected by Seller.

These terms and conditions may be modified, cancelled or rescinded only by a written agreement of both parties executed by their duly authorized agents.

**USE ONLY GENUINE EDCO PARTS & ACCESSORIES**  
**For your own safety, the safety of others and the life of your machine.**

**Equipment Development Company, Inc.**



**EQUIPMENT DEVELOPMENT COMPANY, INC.**  
100 Thomas Johnson Drive, Frederick, MD 21702-4600 USA  
Phone: 800-638-3326 or 301-663-1600 • Fax: 800-447-3326 or 301-663-1607  
Website: www.edcoinc.com • E-mail: sales@edcoinc.com

Printed in USA

©2017

Page 11



## BEFORE USING THIS PRODUCT

Have You Used EDCO's Online Customer Support??



Scan This QRC or Visit  
[www.edcoinc.com/customer-support](http://www.edcoinc.com/customer-support)



**READ: EDCO Owner's Manuals and Parts Listings** share basic information and parts of each product. Download and print them whenever needed.



**WATCH: EDCO Product Training Videos** show how to use products, install tooling, and perform basic maintenance.



*Example Only*

**FIND:** Somewhere on this product is an **EDCO QRC Training Decal**. Scanning this code provides owner's information, videos, and other training content anywhere/anytime on your mobile device.



**JOIN: EDCOed.com** is a free, 24-hour training space. Each certification track focuses on a specific EDCO product group. The information in these tracks help businesses be successful with those products.

EDCO is always updating online training / information so you always have the most recent content.

Also see Operator's Safety & Limited Warranty Manual

Equipment Development Co., Inc. • 800.638.3326 • [techsupport@edcoinc.com](mailto:techsupport@edcoinc.com)